



**CONNECT AND PROTECT**

# Flexible Conductors

IBS/IBSB Advanced Insulated Braided Conductor  
for Circuit Breakers from 125A to 630A

Solutions to Optimize the Design of Electrical Power and Grounding & Bonding Connections

  
nvent

**ERIFLEX**

# Flat Insulated Braided Conductor IBS/IBSB Advanced

## HALOGEN-FREE - LOW SMOKE - FLAME RETARDANT INSULATED BRAIDED CONDUCTOR FOR CIRCUIT BREAKERS



### SPACE AND WEIGHT ADVANTAGE

- nVent ERIFLEX IBS & IBSB Advanced require less wire bending space than traditional cable with greater flexibility
- With greater ampacities, a single piece of IBS & IBSB Advanced can replace multiple runs of cable
- Protective sleeve and flexibility allows IBS & IBSB Advanced to be mounted in tight areas where rigid busbar or rigid cables can not be used
- No clearance distance needed around IBS & IBSB Advanced vs other phases or metallic parts due to Class II insulation characteristics
- Integral solid palm without lugs or terminals reduces material and assembly weight

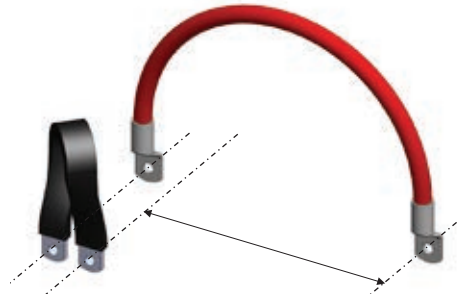

### TIME ADVANTAGE

- IBS & IBSB Advanced is a ready to use conductor that does not require lug or tools to fabricate the conductor, reducing installation time and cost
- Easier to bend and shape than large cables, making installation quicker



### AESTHETIC ADVANTAGE

- Increases design flexibility
- Neatly organizes hard-to-make connections

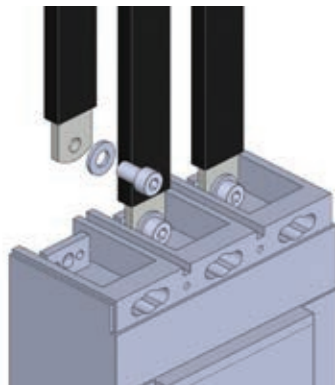

### RELIABILITY & SAFETY ADVANTAGE

- IBS & IBSB Advanced are directly connected thus eliminating the cable lug connection and other source of heating point
- IBS & IBSB Advanced have tinned protected palms for better corrosion resistance
- Excellent resistance to vibration.
- No crimping
- Less human error
- Insulation sleeve manufactured from high-resistance low smoke, halogen-free and flame retardant Thermoplastic (LSHFFR), with a 115°C maximum temperature



### OPERATING ADVANTAGE

- IBS & IBSB Advanced are able to connect on the front access connection of the main molded case circuit breakers
- Ring terminals or lugs are no longer needed as IBS & IBSB Advanced is already punched. No additional crimping operation is needed
- The high working temperature 115°C is better than a standard cable that allow reducing the risk of hot point at the connecting area





nVent ERIFLEX Advanced Technology insulation is a high-resistance low smoke, halogen-free and flame retardant Thermoplastic (LSHFFR), with 115°C high working temperature.

IBS & IBSB Advanced does not generate corrosive gases and produces a relatively **low smoke** opacity in accordance with IEC 61034-2 and UL 2885. The low smoke features improves visibility conditions for people to be able to easily locate the emergency exit and also allows rescue workers to better assess an emergency situation. IBS & IBSB Advanced means greater safety for individuals, less damage for your electrical equipment and less environmental impact.

The **halogen-free** feature enables a reduction in the quantity of toxic smoke. IBS & IBSB Advanced contain no halogens, according to IEC 60754-1 and UL 2885, minimizing toxicity and making it the ideal product for use in enclosed spaces such as data centers, rail and spaces where people are present such as hospitals and schools. This feature also facilitates the use of IBS & IBSB Advanced in specific applications such as submarines, switchboards and other enclosed environments that require a low emissions solution.

In addition to the above features, IBS & IBSB Advanced are compliant with the UL 94-V0 testing standard and Glow wire test 960°C. The **flame retardant** portion of the test illustrates self-extinguishing capabilities. This feature is also shown by the Limiting Oxygen Index (LOI) at 30%. In the case of a fire, IBS & IBSB Advanced generates a limited quantity of smoke that is less damaging to your electrical equipment.













# Main Technical Specifications

## Flat IBS and IBSB Advanced

Material	Electrolytic copper Cu-ETP 99,9% purity Thermoplastic Elastomer
Wire Diameter	0,15 mm
Finish	Tinned
Maximum resistivity at 20°C	0.017241 ohms.mm <sup>2</sup> / m
Dielectric Strength	20 kV/mm
Flammability Rating	UL® 94V-0 IEC® 60695-2-12 (Glow Wire Test 960 °C)
Halogen Free Rating	UL® 2885 IEC® 60754-1 IEC® 62821-2
Low Smoke Rating	UL® 2885 IEC® 61034-2 ISO 5659-2
Typical Insulation Elongation	> 500%
Typical Insulation Thickness	1.8 mm (0,070 inches)
Nominal Voltage	UL/IEC: 1,000 VAC; 1,500 VDC
Working Temperature	-50 to 115 °C (-58 to 239°F)
Certification Details	UL® 67 UL® 758 CSA 90005
Complies With	IEC® 60695-2-12 (Glow Wire Test 960 °C) IEC® 61439.1 IEC® 61439.1 Class II UV rating according to UL 2556 and UL 854 CE RoHS EN 45545 : HL2 classification Marine & Offshore application certified by : DNV-GL, Bureau Veritas, ABS



# Dimension and Packing Unit

Use with Circuit Breaker	Part Number	Article Number	Cross Section mm <sup>2</sup>	Conductor Width mm	Conductor Thickness mm	L mm	A mm	B mm	C mm	D mm	HS1 mm	HS2 mm	
<b>125/160A</b> 	IBSBADV25-230	534400	25	12	2.8	230	7.5	7.5	18	9	6.5	6.5	10
	IBSBADV25-330	534401	25	12	2.8	330	7.5	7.5	18	9	6.5	6.5	10
	IBSBADV25-430	534402	25	12	2.8	430	7.5	7.5	18	9	6.5	6.5	10
	IBSBADV25-530	534403	25	12	2.8	530	7.5	7.5	18	9	6.5	6.5	10
	IBSBADV25-630	534404	25	12	2.8	630	7.5	7.5	18	9	6.5	6.5	10
	IBSBADV25-830	534405	25	12	2.8	830	7.5	7.5	18	9	6.5	6.5	10
	IBSBADV25-1030	534406	25	12	2.8	1030	7.5	7.5	18	9	6.5	6.5	10
	IBSADV25-230	534500	25	20	1.9	230	10	12	25	6	8.5	10.5	10
	IBSADV25-330	534501	25	20	1.9	330	10	12	25	6	8.5	10.5	10
	IBSADV25-430	534502	25	20	1.9	430	10	12	25	6	8.5	10.5	10
	IBSADV25-530	534503	25	20	1.9	530	10	12	25	6	8.5	10.5	10
	IBSADV25-630	534504	25	20	1.9	630	10	12	25	6	8.5	10.5	10
	IBSADV25-830	534505	25	20	1.9	830	10	12	25	6	8.5	10.5	10
	IBSADV25-1030	534506	25	20	1.9	1030	10	12	25	6	8.5	10.5	10
<b>250A</b> 	IBSBADV50-230	534407	50	20	3	230	9	11	27	9	8.5	10.5	10
	IBSBADV50-330	534408	50	20	3	330	9	11	27	9	8.5	10.5	10
	IBSBADV50-430	534409	50	20	3	430	9	11	27	9	8.5	10.5	10
	IBSBADV50-530	534410	50	20	3	530	9	11	27	9	8.5	10.5	10
	IBSBADV50-630	534411	50	20	3	630	9	11	27	9	8.5	10.5	10
	IBSBADV50-830	534412	50	20	3	830	9	11	27	9	8.5	10.5	10
	IBSBADV50-1030	534413	50	20	3	1030	9	11	27	9	8.5	10.5	10
	IBSADV50-230	534507	50	20	3.8	230	12	12	25	7.5	10.5	10.5	10
	IBSADV50-330	534508	50	20	3.8	330	12	12	25	7.5	10.5	10.5	10
	IBSADV50-430	534509	50	20	3.8	430	12	12	25	7.5	10.5	10.5	10
	IBSADV50-530	534510	50	20	3.8	530	12	12	25	7.5	10.5	10.5	10
	IBSADV50-630	534511	50	20	3.8	630	12	12	25	7.5	10.5	10.5	10
	IBSADV50-830	534512	50	20	3.8	830	12	12	25	7.5	10.5	10.5	10
	IBSADV50-1030	534513	50	20	3.8	1030	12	12	25	7.5	10.5	10.5	10
<b>300A</b> 	IBSBADV70-230	534414	70	20	4.3	230	9	11	27	11	8.5	10.5	10
	IBSBADV70-330	534415	70	20	4.3	330	9	11	27	11	8.5	10.5	10
	IBSBADV70-430	534416	70	20	4.3	430	9	11	27	11	8.5	10.5	10
	IBSBADV70-530	534417	70	20	4.3	530	9	11	27	11	8.5	10.5	10
	IBSBADV70-630	534418	70	20	4.3	630	9	11	27	11	8.5	10.5	10
	IBSBADV70-830	534419	70	20	4.3	830	9	11	27	11	8.5	10.5	10
	IBSBADV70-1030	534420	70	20	4.3	1030	9	11	27	11	8.5	10.5	10
<b>350A</b> 	IBSBADV100-230	534421	100	24	5	230	9	11	31	13	8.5	10.5	10
	IBSBADV100-330	534422	100	24	5	330	9	11	31	13	8.5	10.5	10
	IBSBADV100-430	534423	100	24	5	430	9	11	31	13	8.5	10.5	10
	IBSBADV100-530	534424	100	24	5	530	9	11	31	13	8.5	10.5	10
	IBSBADV100-630	534425	100	24	5	630	9	11	31	13	8.5	10.5	10
	IBSBADV100-830	534426	100	24	5	830	9	11	31	13	8.5	10.5	10
	IBSBADV100-1030	534427	100	24	5	1030	9	11	31	13	8.5	10.5	10
<b>400A</b> 	IBSBADV120-230	534428	120	32	4.4	230	11	11	39	12	10.5	10.5	2
	IBSBADV120-330	534429	120	32	4.4	330	11	11	39	12	10.5	10.5	2
	IBSBADV120-430	534430	120	32	4.4	430	11	11	39	12	10.5	10.5	2
	IBSBADV120-530	534431	120	32	4.4	530	11	11	39	12	10.5	10.5	2
	IBSBADV120-630	534432	120	32	4.4	630	11	11	39	12	10.5	10.5	2
	IBSBADV120-830	534433	120	32	4.4	830	11	11	39	12	10.5	10.5	2
	IBSBADV120-1030	534434	120	32	4.4	1030	11	11	39	12	10.5	10.5	2
<b>500A</b> 	IBSBADV185-330	534435	185	32	7.1	330	12	14	39	16	10.5	12.5	2
	IBSBADV185-430	534436	185	32	7.1	430	12	14	39	16	10.5	12.5	2
	IBSBADV185-530	534437	185	32	7.1	530	12	14	39	16	10.5	12.5	2
	IBSBADV185-630	534438	185	32	7.1	630	12	14	39	16	10.5	12.5	2
	IBSBADV185-830	534439	185	32	7.1	830	12	14	39	16	10.5	12.5	2
	IBSBADV185-1030	534440	185	32	7.1	1030	12	14	39	16	10.5	12.5	2
<b>630A</b> 	IBSBADV240-330	534441	240	32	9.2	330	12	14	39	18.5	10.5	12.5	2
	IBSBADV240-430	534442	240	32	9.2	430	12	14	39	18.5	10.5	12.5	2
	IBSBADV240-530	534443	240	32	9.2	530	12	14	39	18.5	10.5	12.5	2
	IBSBADV240-630	534444	240	32	9.2	630	12	14	39	18.5	10.5	12.5	2
	IBSBADV240-830	534445	240	32	9.2	830	12	14	39	18.5	10.5	12.5	2
	IBSBADV240-1030	534446	240	32	9.2	1030	12	14	39	18.5	10.5	12.5	2

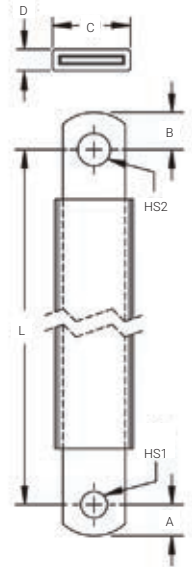

# How to select nVent ERIFLEX IBS & IBSB Advanced

When sizing a conductor, the air temperature around the conductor is a very important parameter, mainly affected by factors such as convection type, protection level of enclosure or the temperature rise. Based on IEC 61439 standards, the ambient air temperature does not exceed +40°C and its average over a period of 24h does not exceed +35°C.

For IBS & IBSB Advanced, we provided an ampacity table under different temperature rise, a lower temperature rise maybe used when the ambient temperature is higher than usual.

## TEMPERATURE RISE OF THE CONDUCTOR.

Temperature rise of the conductor ( $\Delta T$ ) = Temperature of the conductor – Internal temperature of the panel.

• Temperature rise of conductor =  $T_2 - T_1 = \Delta T$  (C°)

### Example:

For a requested current of 630A, with:  $T_1 = 40^\circ\text{C}$  and  $T_2 = 90^\circ\text{C}$

- $\Delta T = 90 - 40 = 50^\circ\text{C}$
- in the  $\Delta T$  50°C column, find the closest current value to 630A

Result: IBSB Advanced 240 mm<sup>2</sup> – 718A (IEC & UL)

For IBS & IBSB Advanced, we recommend the maximum temperature rise does not exceed 50°C for a normal application. Generally, 50°C is chosen as the default temperature rise considering the ambient temperature inside the panel is below 40°C. But when the connected section is an electrical component which may dissipate heat (for example circuit breaker) or the ventilation inside the enclosure is not efficient, it may be necessary to choose lower temperature rise.

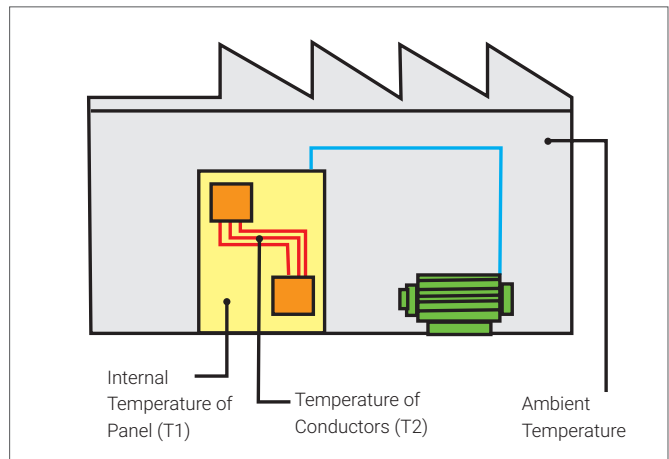

Insulated Braided conductor type	Cross Section mm <sup>2</sup> (kcmil)	Maximum Ampacity Ratings							Current Coefficient	
		$\Delta T$ 30° C (A)	$\Delta T$ 40° C (A)	$\Delta T$ 45° C (A)	$\Delta T$ 50° C (A)	$\Delta T$ 55° C (A)	$\Delta T$ 60° C (A)	$\Delta T$ 70° C (A)		
IBSB ADV 25	25 (49.34)	116	134	142	150	157	164	177	1.6	2
IBS ADV 25	25 (49.34)	137	158	167	177	185	193	209	1.6	2
IBS ADV 50 IBSB ADV 50	50 (98.68)	213	246	260	274	288	301	325	1.6	2
IBSB ADV 70	70 (138.15)	226	261	277	291	306	319	345	1.6	2
IBSB ADV 100	100 (197.35)	298	344	365	385	404	422	456	1.6	2
IBSB ADV 120	120 (236.82)	363	419	444	468	491	513	554	1.6	2
IBSB ADV 185	185 (365.1)	416	480	509	537	563	588	635	1.6	2
IBSB ADV 240	240 (473.65)	556	642	681	718	753	786	849	1.6	2

Admissible currents: This table indicates the temperature rise produced by chosen current in the given section. This calculation does not take into account the heat dissipation from the switch gear.

## IBS & IBSB ADVANCED IN PARALLEL

When using 2 or 3 IBS & IBSB Advanced in parallel for the same phase, use the current coefficient showed on the above IEC & UL ampacities table.

### Example:

IBSB Advanced 240 mm<sup>2</sup> –  $\Delta T = 50^\circ\text{C}$ : 718 A (IEC & UL)

- 2 Braids in parallel: 718 A x 1,6 = 1149 A
- 3 Braids in parallel: 718 A x 2 = 1436 A

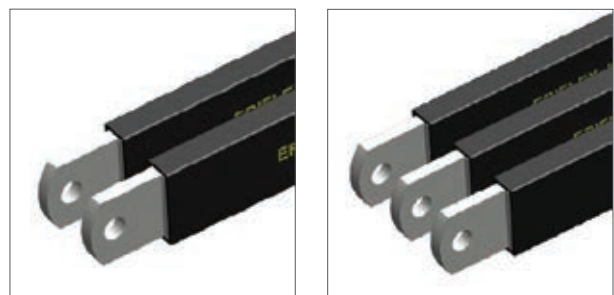

# IBS & IBSB Advanced Connection on Molded Case Circuit Breaker

The IBS & IBSB Advanced range can be used as an alternative to cable for all low-voltage applications. It is suitable and connectable for molded case circuit breaker ranges, including most compact breakers on the market. From 80A up to 630A circuit breakers, you can directly connect the IBS & IBSB Advanced on the front access terminals breaker without additional accessories, such as angular connectors, spreaders, ring terminal connectors or extenders. No lugs and no cutting, stripping or crimping are necessary.

**Simple, quick, ready to use!**

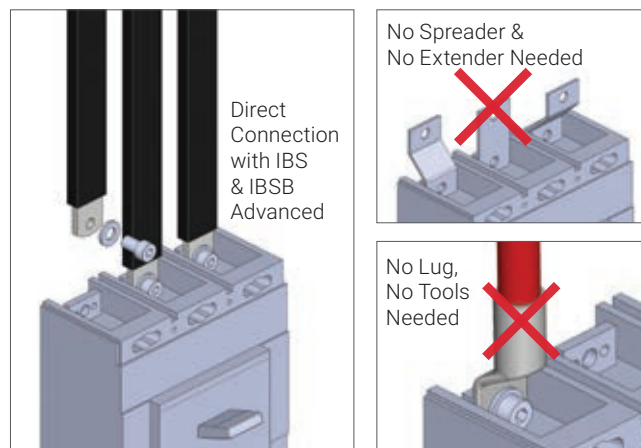

## CIRCUIT BREAKER COMPATIBILITY

Circuit Breaker Current Rating	125/160 A		250 A		300 A	350 A	400 A	500 A	630 A
Insulated Braided conductor type	IBSB ADV 25x	IBS ADV 25x	IBSB ADV 50x	IBS ADV 50x	IBSB ADV 70x	IBSB ADV 100x	IBSB ADV 120x	IBSB ADV 185x	IBSB ADV 240x
Schneider Electric Compact (IEC)	NSA NG 125	NSX 100 NSX 160	NSX 250	NSX 250	NSX 400	NSX 400	NSX 400	NSX 630	NSX 630
Square D PowerPact (UL)	H-Frame	J-Frame	J-Frame	J-Frame	L-Frame	L-Frame	L-Frame	–	–
ABB Tmax (IEC)	T1 T2 XT1 XT2	–	T3 XT3 XT4	T3 XT3 XT4	T4	T4	T5	T5	T5
ABB Tmax (UL)	T1 T2 XT1 XT2	T3	T4 XT3 XT4	T4 XT3 XT4	T5	T5	T5	–	–
GE Record Plus (IEC/UL)	FD 160	FE 160	FE 250	FE 250	FG 400	FG 400	FG 400	FG 630	FG 630
Siemens Sentron (IEC/UL)	VL160X 3VL1 VL160 3VL2	–	VL250 3VL3	VL250 3VL3	VL400 3VL4	VL400 3VL4	VL400 3VL4	–	–
Moeller xEnergy (IEC)	NZM1	–	NZM2	NZM2	NZM3	NZM3	NZM3	NZM3	NZM3
Cutler Hammer Series G (UL)	EG Frame	JG Frame	JG Frame	JG Frame	LG Frame	LG Frame	LG Frame	LG Frame	LG Frame
Legrand (IEC)	DPX 160 DPX3 160	–	DPX 250 DPX3 250	DPX 250 DPX3 250	DPX 630	DPX 630	DPX 630	DPX 630	DPX 630
Hager (IEC)	h3 160	–	h3 250	h3 250	h3 630	h3 630	–	–	–
Rockwell/Allen Bradley (UL)	G-Frame H-Frame	–	I-Frame J-Frame	I-Frame J-Frame	I-Frame J-Frame	–	K-Frame	K-Frame	–
Mitsubishi Electric (IEC)	–	NF125 NF160 DSN125 DSN160	NF250 DSN250	NF250 DSN250	–	NF400 DSN400	–	–	–
OEZ (IEC)	BC160N	–	BD250N BD250S	BD250N BD250S	BH630B BH630S	BH630B BH630S	BH630B BH630S	BH630B BH630S	BH630B BH630S

This table does not take into account the specific installation environment, like ambient temperature, protection level of enclosure, altitude, frequency.

Some MCCB may need more important cross section in function of the MCCB Power dissipation. In some cases, increasing the IBS & IBSB Advanced cross section may be necessary to support MCCB heating dissipation. It is therefore necessary to respect the instructions provided by the electrical device manufacturer.



# Round Insulated Braided Conductor IBS Advanced

IBS 120  
IBS 185  
IBS 240

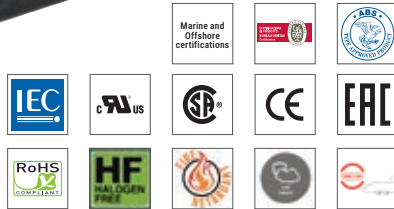

## FEATURES

- Resistant to vibration, improving reliability and performance
- Insulated by high-resistance, halogen free, flame retardant and low smoke material
- Tinned copper provides superior corrosion resistance
- Improves assembly flexibility and aesthetics
- Quick and easy installation
- No additional cutting, stripping, crimping and punching needed

## INSULATION

- Dielectric Strength: 20 kV/mm
- Insulation Elongation: 500 %
- Insulation Thickness: 1.8 mm
- Max Working Voltage, IEC/UL 758: 1,000 VAC; 1,500 VDC
- Max Working Voltage, UL 67: 600 VAC/DC
- Working Temperature: -50 to 115 °C
- Certification Details: UL® 67; UL® 758
- Complies With: IEC® 60695-2-11 (Glow Wire Test 960 °C); IEC® 61439.1; IEC® 61439.1 Class II
- UV rating according to UL 2556 and UL 854

## BRAID

- Tinned electrolytic copper for better corrosion protection
- Wire diameter: 0.15 mm for maximum flexibility

## CERTIFICATION & APPROVAL

- Flammability Rating: UL® 94V-0
- Halogen Free Rating: UL® 2885; IEC® 60754-1; IEC® 62821-1
- Low Smoke Rating: IEC® 61034-2; ISO 5659-2; UL® 2885
- IEC 61439.1
- cRUus per UL67 & CAN/CSA C22.2 No. 29
- CE conformity
- RoHS compliant
- RU per UL758
- American Bureau of Shipping (ABS) Bureau Veritas : Marine & Offshore application.
- CSA C22.2 No 210 for appliance wiring material products
- Conforms to NF EN 45545 obtaining an HL2 classification for chapters R22 and R23

## DIELECTRIC TEST

- 3500 VAC, 1 minute according to the IEC 61439 standard (rated insulation voltage  $U_i$  1000 VAC)
- 6000 VAC, 1 minute with 6 mA creepage current set up

## TECHNICAL DATA

- Intensity = 100A up to 1000A
- Excellent electrical contact
- Good tensile strength





# Round Insulated Braided Conductor IBS Advanced

IBS 120  
IBS 185  
IBS 240

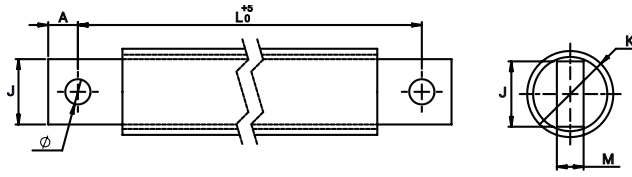

	Part No.	IBS 120	S mm <sup>2</sup>	L mm	Ø mm	A mm	J mm	M mm	K mm		Kg
400 A	534514	IBS 120-330-10	120	330	10,5	12	24	10	27	2	0,51
	534515	IBS 120-430-10	120	430	10,5	12	24	10	27	2	0,67
	534516	IBS 120-530-10	120	530	10,5	12	24	10	27	2	0,82
	534517	IBS 120-630-10	120	630	10,5	12	24	10	27	2	0,98
	534518	IBS 120-830-10	120	830	10,5	12	24	10	27	2	1,29
	534519	IBS 120-1030-10	120	1030	10,5	12	24	10	27	2	1,6

	Part No.	IBS 185	S mm <sup>2</sup>	L mm	Ø mm	A mm	J mm	M mm	K mm		Kg
500 A	534520	IBS 185-330-10	185	330	10,5	12	24	15	31	2	0,82
	534521	IBS 185-430-10	185	430	10,5	12	24	15	31	2	1,07
	534522	IBS 185-530-10	185	530	10,5	12	24	15	31	2	1,26
	534523	IBS 185-630-10	185	630	10,5	12	24	15	31	2	1,48
	534524	IBS 185-830-10	185	830	10,5	12	24	15	31	2	1,9
	534525	IBS 185-1030-10	185	1030	10,5	12	24	15	31	2	2,3

	Part No.	IBS 240	S mm <sup>2</sup>	L mm	Ø mm	A mm	J mm	M mm	K mm		Kg
630 A	534526	IBS 240-330-12	240	330	12,5	13	32	15	36	2	1,03
	534527	IBS 240-430-12	240	430	12,5	13	32	15	36	2	1,34
	534528	IBS 240-530-12	240	530	12,5	13	32	15	36	2	1,65
	534529	IBS 240-630-12	240	630	12,5	13	32	15	36	2	1,96
	534530	IBS 240-830-12	240	830	12,5	13	32	15	36	2	2,58
	534531	IBS 240-1030-12	240	1030	12,5	13	32	15	36	2	3,2

Insulated Braided conductor type	Section mm <sup>2</sup>	$\Delta T$ (K)							Current Coefficient
		30	40	45	50	55	60	70	
IBS 120	120	325	376	398	420	441	460	497	1,6
IBS 185	185	407	470	499	526	552	576	622	1,6
IBS 240	240	488	563	598	630	661	690	745	1,6

ADMISSIBLE CURRENTS: This table indicates the temperature rise produced by chosen current in the given section. This calculation does not take into account the heat dissipation from the switch gear.

# Advanced Insulated Braided IBSHY Conductor for Compact Circuit Breakers



## FEATURES

- Suitable for all main 125/160 A electrical devices and specifically molded case circuit breakers
- Resistant to vibration, improving reliability and performance
- Improves assembly flexibility and aesthetics
- Quick and easy installation
- No additional cutting, stripping, crimping and punching needed
- Small wire diameter provides maximum flexibility
- Halogen-free solution for applications requiring a low smoke solution
- DNV-GL certified busbar systems for electrical installation for ship and marine application
- Conforms to NF EN 45545 obtaining an HL2 classification for chapters R22 and R23
- High working temperature
- RoHS compliant



## IBSHY INSULATED BAIED CONDUCTOR SPECIFICATIONS

- Typical Application Current Rating: 160 A
- Finish: Tinned
- Material: Copper; Glass Fibre Reinforced Silicon
- Flammability Rating: UL 1441 VW-1
- Max Working Voltage, IEC (U<sub>i</sub>): 1 000 VAC; 1 500 VDC
- Operating Temperature: from -60 °C to 250 °C
- Wire Diameter: 0.15 mm
- IEC 61439-1 compliant

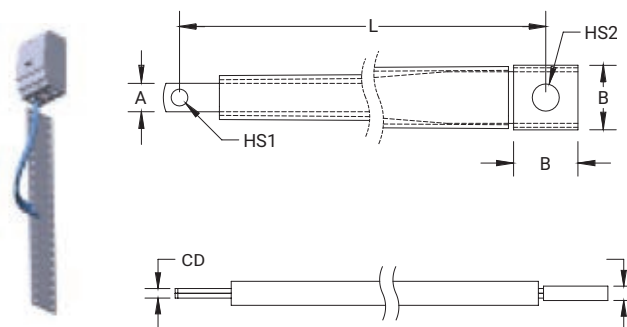



### IBSHY ADVANCED INSULATED BAIDED CONDUCTOR TECHNICAL CHARACTERISTICS

Part No.	Article No.	Cross Section	Length L	A	B	C	D	Hole Size 1 HS1	Hole Size 2 HS2
IBSHY32-230	558584	32 mm <sup>2</sup>	230 mm	11 mm	25 mm	3 mm	5 mm	6.5 mm	10.5 mm
IBSHY32-330	558586	32 mm <sup>2</sup>	330 mm	11 mm	25 mm	3 mm	5 mm	6.5 mm	10.5 mm
IBSHY32-365	558587	32 mm <sup>2</sup>	365 mm	11 mm	25 mm	3 mm	5 mm	6.5 mm	10.5 mm
IBSHY32-430	558588	32 mm <sup>2</sup>	430 mm	11 mm	25 mm	3 mm	5 mm	6.5 mm	10.5 mm
IBSHY32-500	558589	32 mm <sup>2</sup>	500 mm	11 mm	25 mm	3 mm	5 mm	6.5 mm	10.5 mm
IBSHY32-565	558591	32 mm <sup>2</sup>	565 mm	11 mm	25 mm	3 mm	5 mm	6.5 mm	10.5 mm
IBSHY32-630	558592	32 mm <sup>2</sup>	630 mm	11 mm	25 mm	3 mm	5 mm	6.5 mm	10.5 mm
IBSHY32-700	558593	32 mm <sup>2</sup>	700 mm	11 mm	25 mm	3 mm	5 mm	6.5 mm	10.5 mm
IBSHY32-765	558594	32 mm <sup>2</sup>	765 mm	11 mm	25 mm	3 mm	5 mm	6.5 mm	10.5 mm
IBSHY32-830	558595	32 mm <sup>2</sup>	830 mm	11 mm	25 mm	3 mm	5 mm	6.5 mm	10.5 mm

Maximum Ampacity Ratings															
Cross Section (mm <sup>2</sup> /kcmil)	ΔT 30° C (A)	ΔT 35° C (A)	ΔT 40° C (A)	ΔT 45° C (A)	ΔT 50° C (A)	ΔT 55° C (A)	ΔT 60° C (A)	ΔT 65° C (A)	ΔT 70° C (A)	ΔT 75° C (A)	ΔT 80° C (A)	ΔT 100° C (A)	ΔT 120° C (A)	2 Bar Current Coefficient	3 Bar Current Coefficient
32/63.15	142	153	164	174	184	193	201	209	217	225	235	263	290	1.6	2

ΔT = Temperature of conductors – Internal temperature of panel.

This table indicates the temperature rise produced by chosen current in the given section. This calculation does not take into account the heat dissipation from the switch gear.



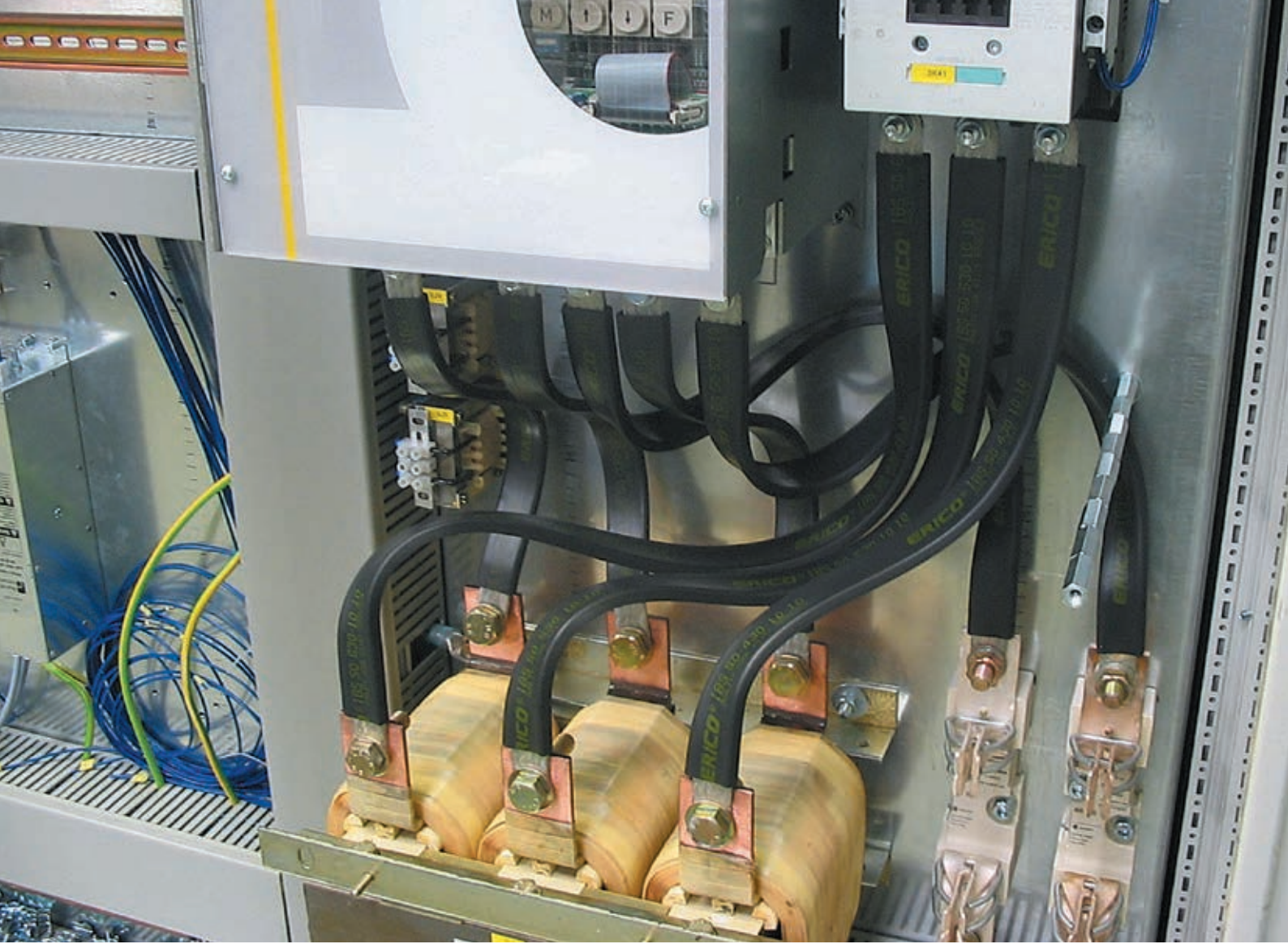

## ASSEMBLY INSTRUCTIONS

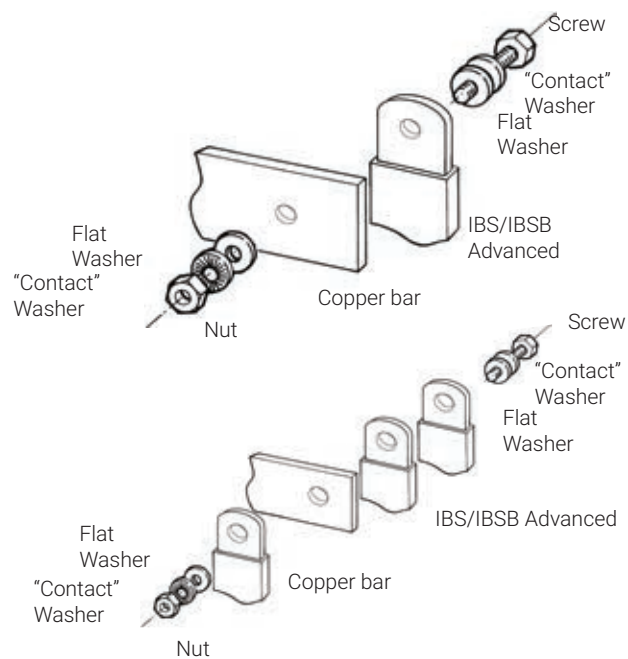

Space between 2 or 3 insulated braided conductors in parallel, for cooling.

A minimum air gap is required. Use FS type spacer clamp.

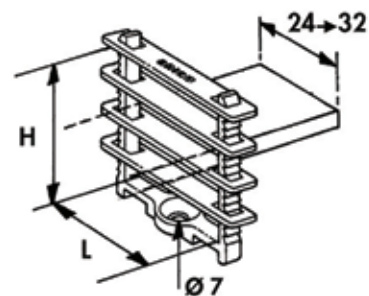

Designation	Part No.	For insulated braided conductor type
FS 24	553550	IBS Advanced 25 / 50 IBSB Advanced 25 / 50 / 70 / 100
FS 32	553560	IBSB Advanced 120 / 185 / 240



Our powerful portfolio of brands:

**CADDY ERICO HOFFMAN RAYCHEM SCHROFF TRACER**



[nVent.com/ERIFLEX](https://www.nVent.com/ERIFLEX)