

Features:

- Universal AC input / Full range
- Programmable output Voltage / Current (0% ~ 105%)
- Built-in active PFC Function , Oring Diode & RS485
- Forced current sharing at parallel operation
(Refer to pg. 5 for connection diagram)
- Constant current limit
- Selectable +5V / 0.5A or +9V / 0.3A auxiliary output
- Global control via RS232 / 485
- Remote setting multiple PSU via RS232, Rs485 & I²C
- Power OK signal
- Remote ON / OFF function
- Protection: OVP, OLP, OTP, SCP, Fan failure



MODEL		AEK-3000-150	AEK-3000-200	AEK-3000-250	AEK-3000-300	AEK-3000-400
Output	DC Voltage Rated	150V	200V	250V	300V	400V
	Rated Current	20A	15A	12A	10A	7.5A
	Current Range	0 ~ 20A	0 ~ 15A	0 ~ 12A	0 ~ 10A	0 ~ 7.5A
	Rated Power	3000W				
	Ripple & Noise (Max.)	Note.2 1500mVp-p	2000mVp-p	2500mVp-p	3000mVp-p	4000mVp-p
	Voltage Adj. Range	±5.0% Typical adjustment by potentiometer. (Via V-Adj from PSU front panel)				
	Voltage Tolerance	Note.3 ±2.0% (rated output voltage of single unit)				
	Current Tolerance	±3.0% (rated output current of single unit)				
	Line Regulation	±1.0%				
	Load Regulation	±1.0%				
Input	Voltage Range	Note.4 90 ~ 264VAC, 127 ~ 370VDC (Refer to de-rating curve)				
	Frequency Range	47 ~ 63Hz				
	Power Factor (Typ.)	0.95 / 230VAC, 0.98 / 115VAC at full load				
	Efficiency (Max.)	91%			92%	
	AC Current (Max.)	19.7A / 115VAC (2000W), 14.5A / 230VAC (3000W)				
	Inrush Current (Typ.)	33A / 115VAC, 65A / 230VAC				
	Leakage Current	< 3.5mA / 240VAC				
Protection	Over Load	105% rated output power Protection type: Constant current limit				
	Over Voltage	Variable OVP Refer to VCI VS OVP curve.(OVP Tolerance 7%) Protection type: Latch-style (Recovery after reset AC power ON or inhibit)				
	Over Temperature	85 ±5°C detect on NTC, Protection type: Auto recovery after temperature goes down				
Function	Auxiliary Power	Selectable +5V / 0.5A or +9V / 0.3A auxiliary output				
	Remote ON / OFF Control	By external switch				
	Power OK Signal	Open drain signal low when PSU turns on, Max. sink current: 20mA, Max. drain voltage: 40V.				
	Output Voltage Trim	Adjustment of output voltage is between 0 ~ 105% of rated output				
	Output Current Trim	Adjustment of output current is between 0 ~ 105% of rated output				
	Parallel (Current Sharing)	Note.5 Please refer to page 5				
	Communication Interface	Built-in RS485. I ² C & RS232 (Optional)				
Environment	Communication Protocol	RS232, RS485 and I ² C				
	Working Temp.	-20 ~ +60°C (Refer to de-rating curve)				
	Working Humidity	20 ~ 90% RH non-condensing				
	Storage Temp. & Humidity	-40 ~ +85°C, 10 ~ 95% RH				
	Temp. Coefficient	±0.02% / °C (0 ~ 50°C)				
	Vibration	10 ~ 500Hz, 2G 10min. / 1cycle, period for 60min. each along X, Y, Z axes Compliance to IEC 60068-2-6, IEC 60068-2-64				
Safety & EMC	Safety Standards	Certified EN 62368-1; UL62368-1				
	Withstand Voltage	Note.7 I/P-O/P:3KVAC(4242VDC),I/P-FG:1.5KVAC(2121VDC),O/P-FG:0.5KVAC(707VDC)				
	Isolation Resistance	I/P-O/P, I/P-FG, O/P-FG: 100M Ohms / 500VDC (25°C/70%)				
	EMI Conduction Radiation	Certified EN 55032				
	Power Harmonic & Voltage Fluctuation and Flicker	Certified EN 61000-3-2; EN 61000-3-3				
Others	EMS Immunity	Certified EN 55024; IEC 61000-4-2,3,4,5,6,8,11				
	Cooling	Load and temperature control fan				
	Dimension (WxHxD)	170x64x280 mm / 6.69x2.52x11.02 inch				
Note	Packing	3.3kg; 6pcs / 22.7kg / 2.48CUFT				
	<p>1. All parameters NOT specially mentioned are measured at 230VAC input, rated load and 25°C of ambient temperature. 2. Ripple & noise are measured at 20MHz of bandwidth by using a 12" twisted pair-wire terminated with a 0.1uF & 47uF parallel capacitor. 3. Tolerance: includes setup time tolerance, line regulation and load regulation. 4. De-rating may apply in low input voltage. Please check the de-rating curve for more details. 5. In parallel connection only one unit will operate if the total output load is less than 5% of the rated power. 6. The power supply is considered a component which will be installed into a final equipment. The final equipment must be re-confirmed that it still meets EMC directives 7. This test is done without enclosure: I/P-O/P 4242VDC. If with enclosure: I/P-O/P 2121VDC, I/P-FG:2121VDC, O/P-FG: 707VDC</p>					

Mechanical Drawings:

Unit:mm / inch

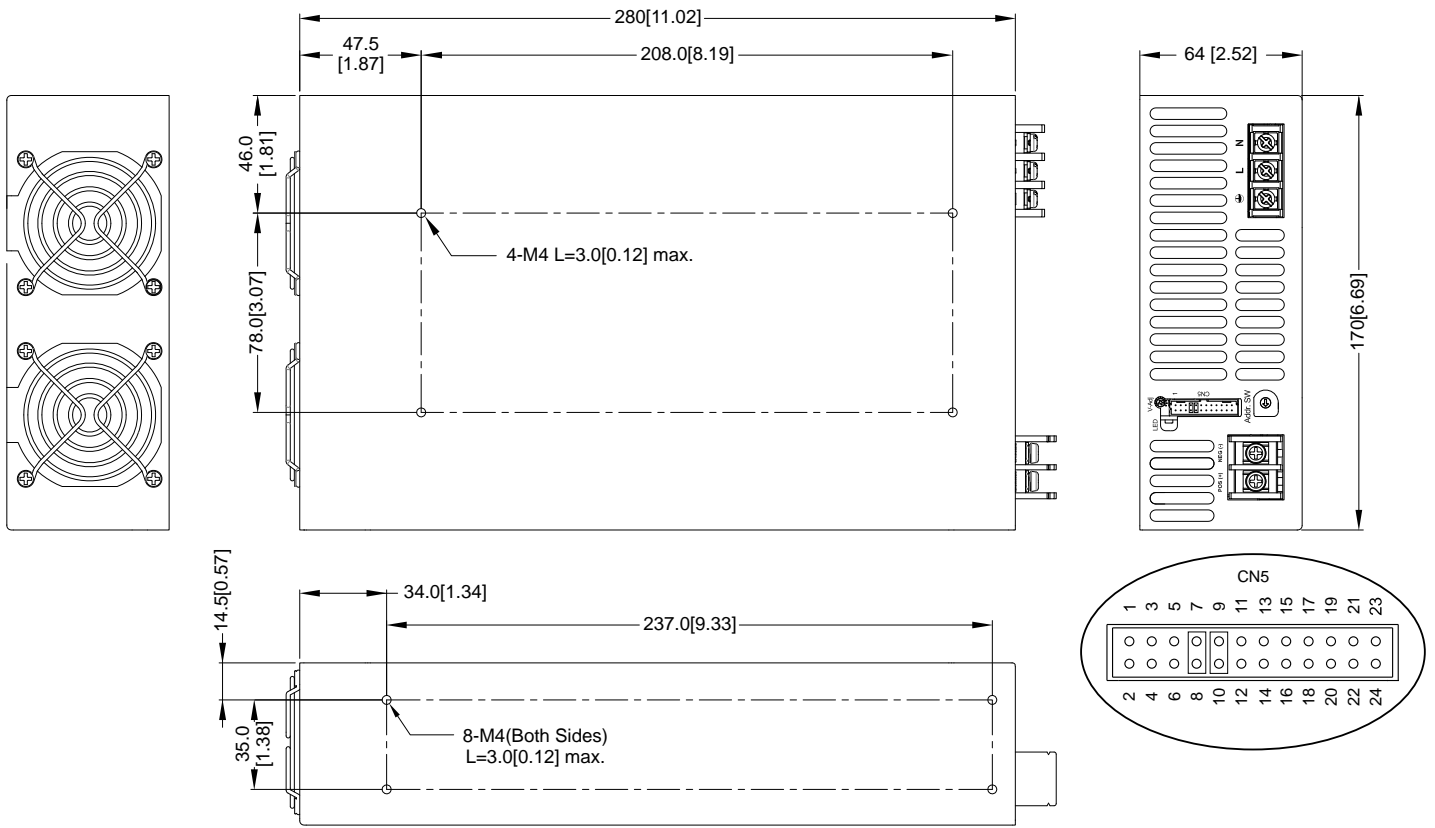

Recommended screw length is measured from the power supply surface

AC Input Terminal Pin No. Assignment

Pin No.	Assignment
L	ACL
N	ACN
⏏	⏏

Control pin number assignment (CN5): JST S24B-PHDSS or equivalent

Pin No.	Assignment	Pin No.	Assignment	Pin No.	Assignment	Mating Housing / Contact	
1	AUX	9	EN+	17	NC.	JST PHDR-24VS or equivalent	JST SPHD-002T-P0.5 or equivalent
2	GND	10	AUX	18	NC.		
3	POK	11	ACI	19	+5VC		
4	GND	12	GND	20	GND1		
5	PAR	13	VCI	21	SCL		
6	VSET	14	GND	22	SDA		
7	EN-	15	AUX	23	DA-		
8	GND	16	GND	24	DA+		

CN5 Function Description:

Pin No.	Function	Description	Pin No.	Function	Description
1	AUX	+5V / 0.5A or +9V / 0.3A Auxiliary power	13	VCI	V Program
2	GND	Ground	14	GND	Ground
3	POK	Power OK	15	AUX	+5V / 0.5A or +9V / 0.3A Auxiliary power
4	GND	Ground	16	GND	Ground
5	PAR	Parallel operation current share	17	NC.	
6	VSET	Aux output setting	18	NC.	
7	EN-	Inhibit ON/OFF (-)	19	+5VC	+5V power supply ,needs to be used with GND1
8	GND	Aux output setting	20	GND1	Ground ,needs to be used with +5VC
9	EN+	Inhibit ON/OFF (+)	21	SCL	Serial Clock for I ² C interface
10	AUX	+5V / 0.5A or +9V / 0.3A Auxiliary power	22	SDA	Serial Data for I ² C interface
11	ACI	I Program	23	DA-	For RS485 Data- Interface
12	GND	Ground	24	DA+	For RS485 Data+ Interface

LED Status:

LED	LED Signal	Status
Solid(Green)		Power OK (Local mode)
Solid(Orange)		Power OK (Remote mode)
Slow Blink(Green)		Power Standby
Fast Blink(Red)		Over Voltage Protection (OVP)
Solid(Red)		Over Load Protection (OLP)
Slow Blink(Red)		Over Temperature Protection (OTP)
Intermittent Blink(Red)		Fan Failure
Interface Blink(Red)		Power Failure

*Local mode : Use ACI/VCI control output current and voltage.
Remote mode : Use RS-232/485 or I²C command control output current and voltage.

De-rating Curve:

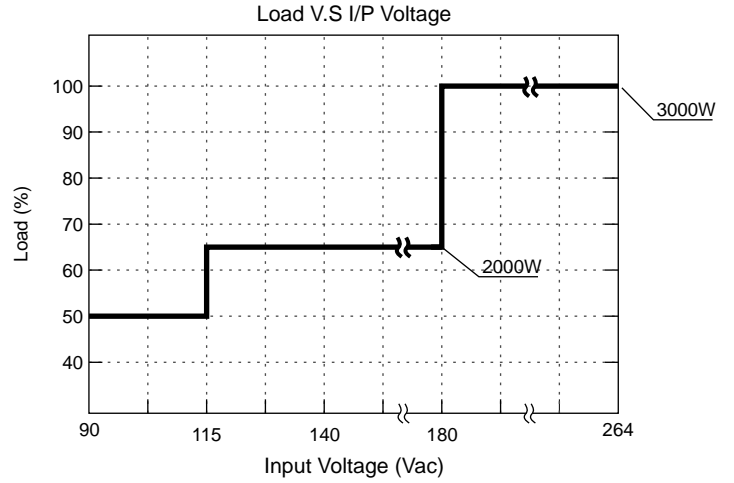
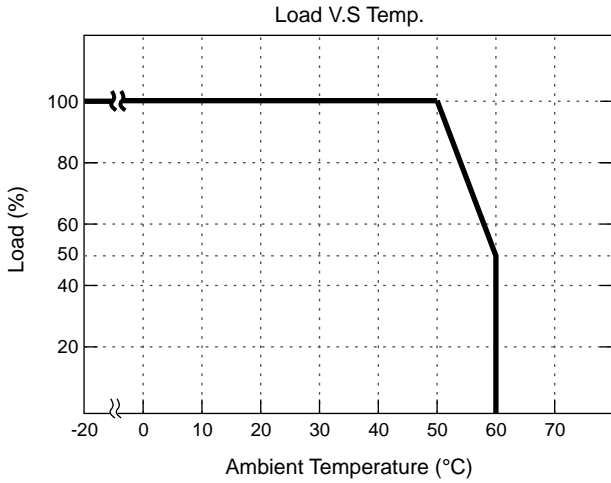

CMD VS Output Curve:

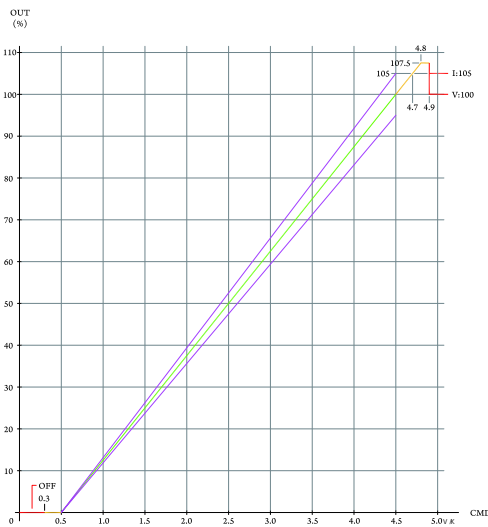

To ensure the power supply output voltage and current could be accurately adjusted, please make sure to adjust the output voltage and current > 10% vs. the rated voltage and current. (e.g. for a 300V unit, please adjust the DC output voltage above 30V to ensure accuracy; same applies to the output current)

VCI VS OVP Curve:

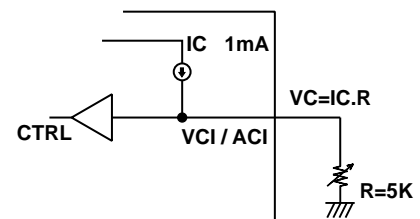
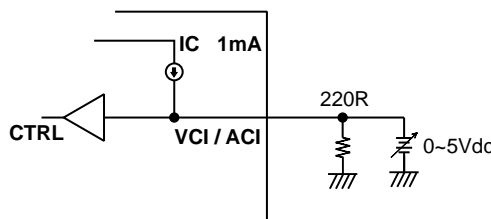
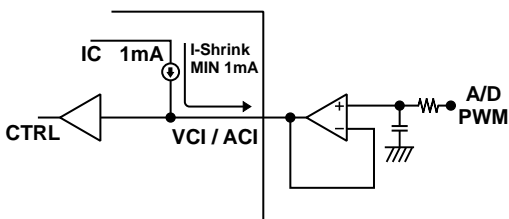
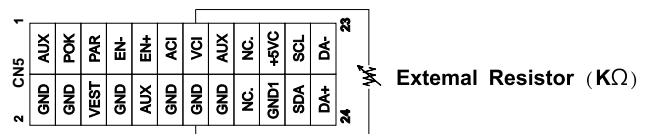
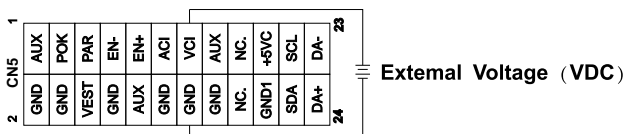
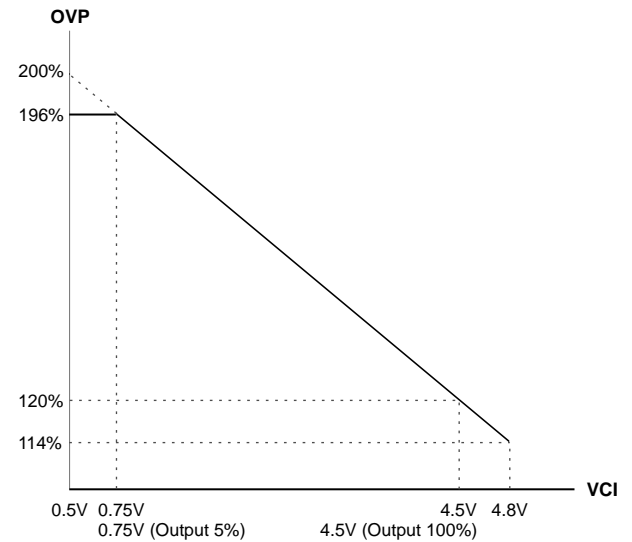

Remote ON/OFF:

(A) Default Setting

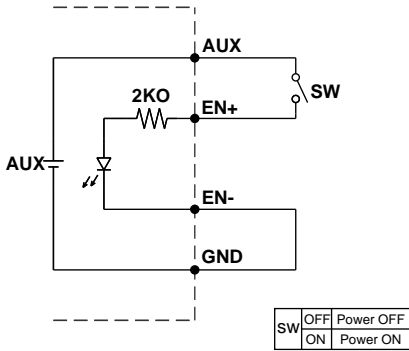

(A) Using internal 5V auxiliary source

(B)

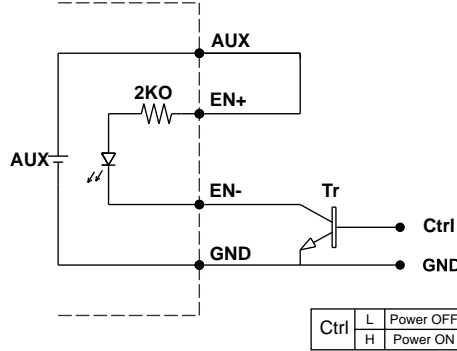

(B) ON / OFF Control by NPN transistor

(C)

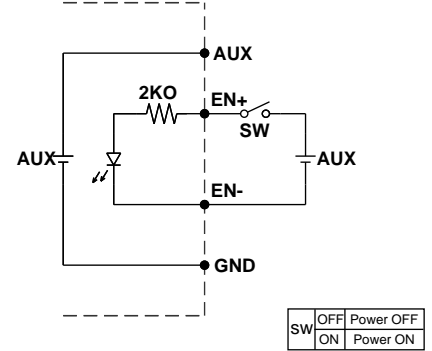

(C) Using external voltage source

GND shown in above diagram is referring to the GND of CN5, not the Grounding from main power(NEG-).

Power OK Signal & Auxiliary Power Setting:

*The grounding of "AUX" power and P.OK signal should be connected to "GND" port. If "VO-" is connected as Grounding, make sure to short the GND and VO- ports.

Open drain signal low when PSU turns on, Max. P.OK sink current: 20mA, Max. drain voltage: 40V.

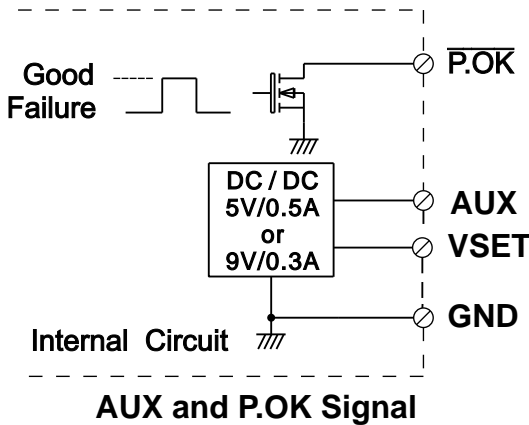

AUX and P.OK Signal

GND shown in above diagram is referring to the GND of CN5, not the Grounding from main power(NEG-).

*Place an additional capacitor to have a better performance of auxiliary power operation.

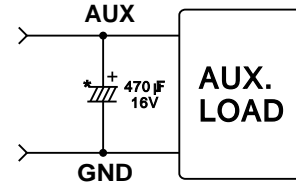

Do NOT exceed 5V/0.5A or 9V/0.3A

RS485 communication connection diagram

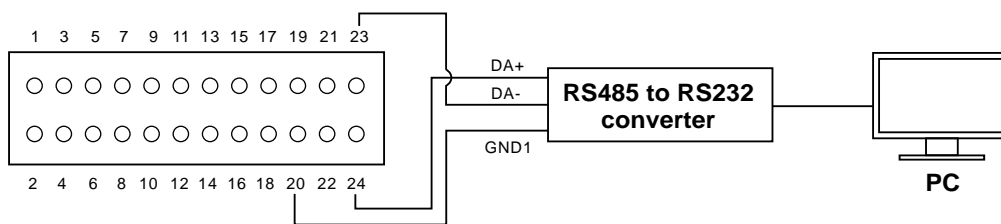

*The ground of the communication signal must use "GND1" (PIN 20)

1. Current Sharing

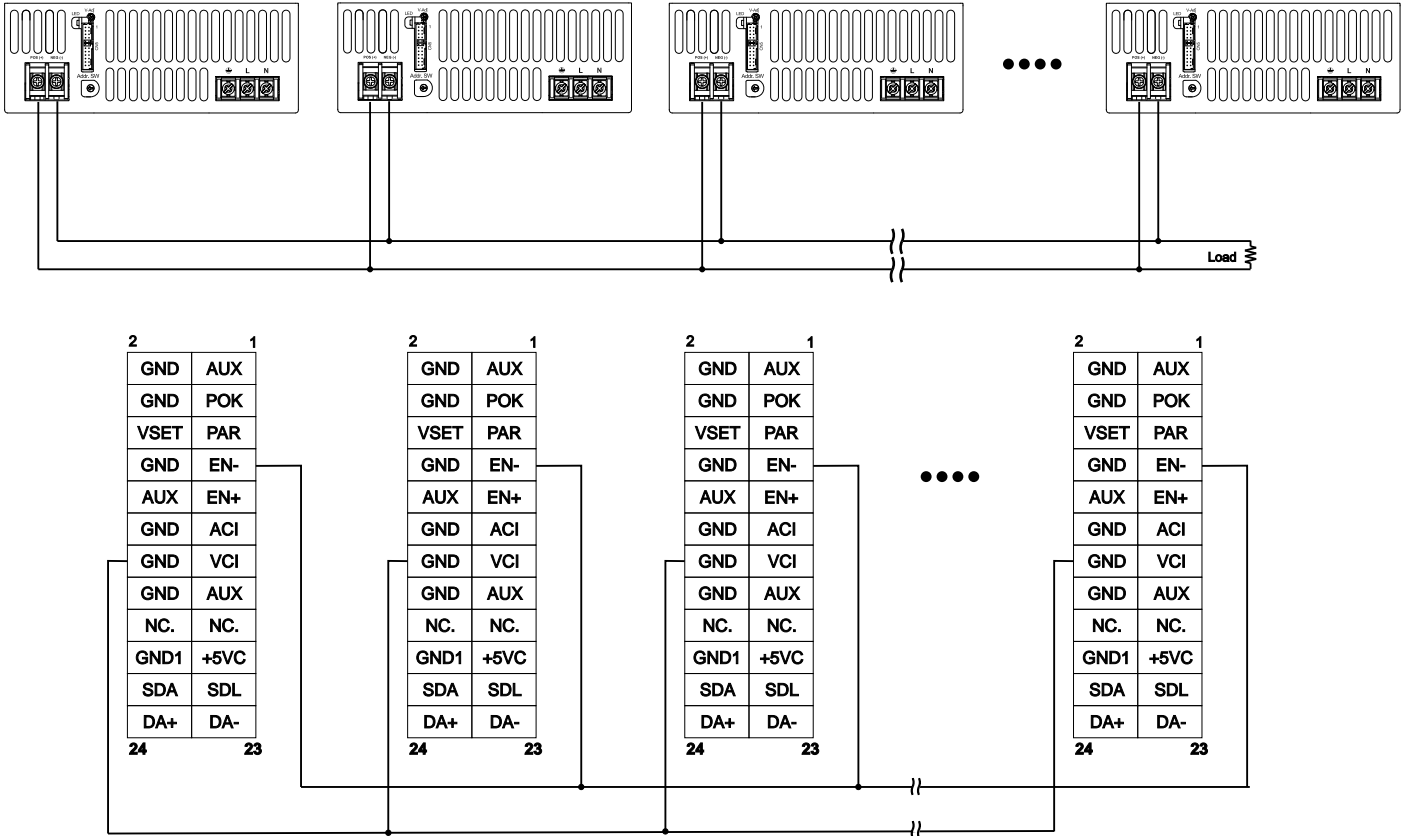

Remarks:

1. AEK-3000-HV Oring diode has the built-in active current sharing function to support max. of 8pcs connected in parallel condition to support higher output power. When performing parallel connection, make sure to note the followings:
 - a. Please connect PAR pins together for current sharing function
 - b. Among the parallel connection units, output voltage difference of each PSU should be <math><0.2VDC</math> (This can be set via V-adj from the PSU front panel VR)
 - c. Total output current must not exceed 90% of the rated power in parallel condition
Maximum output current at parallel condition = rated current per unit x number of unit x 0.9
 - d. To ensure current share balance, output current of each unit must be >10% vs. the rated output current
2. For Series connection, please find some of the remarks as follow:
 - a. Max. units for series connection is 2pcs
 - b. Total output current must not exceed 90% of the rated power in series condition
maximum output current at series condition = rated current per unit x 0.9
 - c. Make sure to isolate all the signals from CN5, except I²C/RS485, Pin 19, 20 and +5VC

Installation Instruction:

1. Mounting Directions

1-1 Recommended standard mounting methods :

(a)

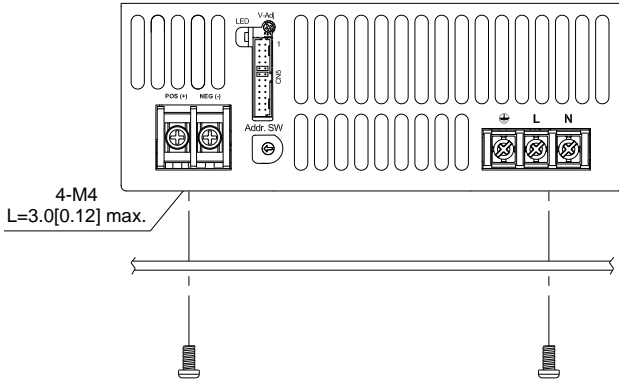

(b)

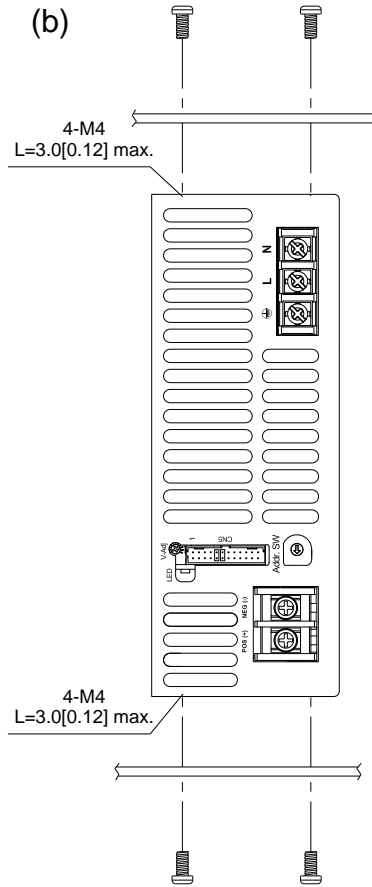

(c)

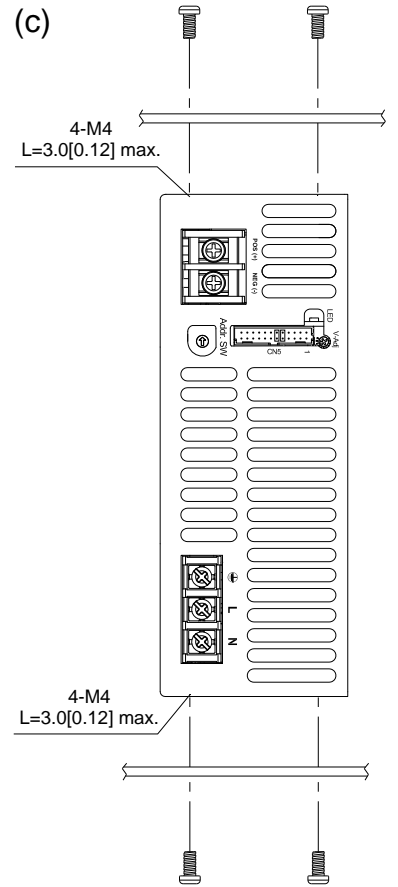

Recommended screw length is measured from the power supply surface

2. Mounting Method

2-1 There are ventilating holes on the front and back side panels, do not obstruct; allow 50mm at least for air flow.

2-2 The Maximum allowable penetration of screw is 3mm. Incomplete threading should not be penetrated .

2-3 Recommended the torque of mounting screw:
M4 screw: 1.27N · m (13.0kgf · cm)

